



JUPITER 25

VARCAS

01 | Multi- Point Locking

Multiple locking with a sleek lock body.

02 | Interlock Male-Female Locking

The two pieces of the interlock lock together in their V-shaped grooves, eliminating the racking sound caused by wind and making the interlock air, water, and dust-proof.

03 | DGU Provision/DGU Glass

DGU Glass offer benefits such as improved thermal insulation, energy efficiency, noise reduction & enhanced security..

04 | Water Outled

Water drainage system is provided.

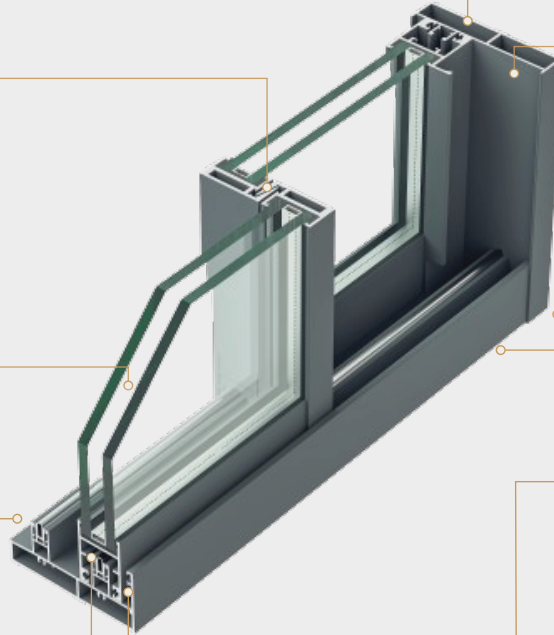

05 | Plain Side Track

The open space which is exposed to the interior side is designed plain for an extra aesthetic look.

06 | 90° Joivery

All the fitments of sections are done at 90°

07 | Conceal Provision Shutter Guide

A shutter guide is provided in the bottom frame which helps to conceal the whole system. For a seamless view.

08 | Wool Pile With Fin Seal

A high-quality brush is used for all weather effects and for a better operating experience.

09 | S.S Roller And Rail

Stainless steel has high strength and load bearing capacity, which is importance for supporting weight of the window sash & facilitating smooth and effortless operation

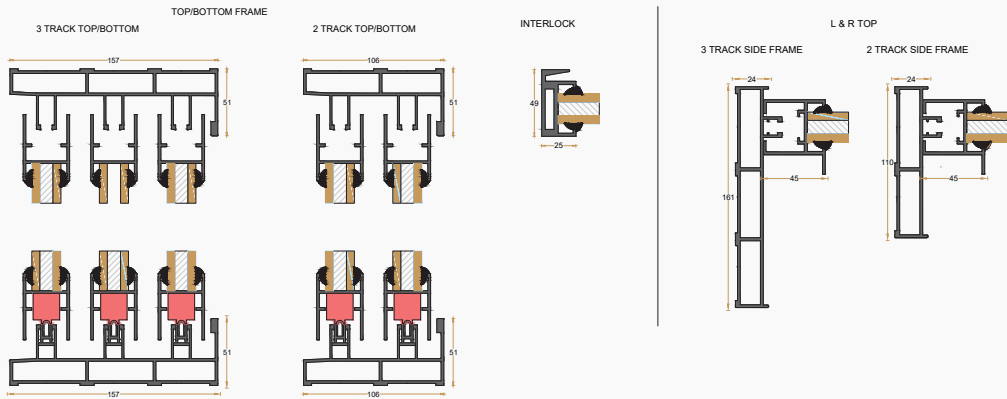
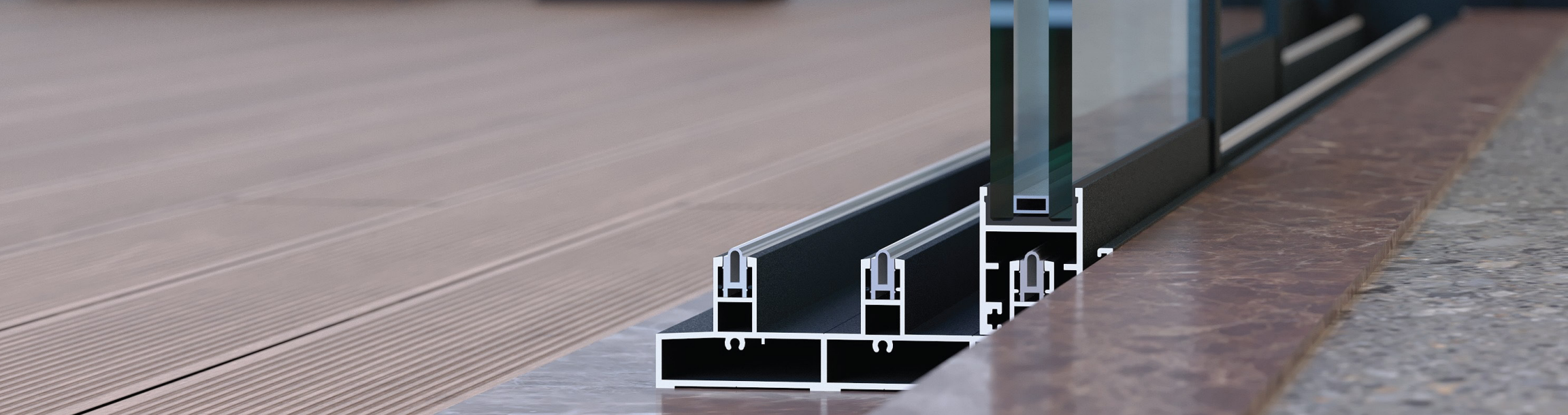

Attributes

Details

Sight Line Face Width	25mm
Face width	45mm
Frame height	50mm
Frame width	33mm
Profile thickness	2.5mm to 5.25mm
Max height of shutter	14 Feet
Max size of shutter	49 sqft
Glazing	6mm to 28mm



Varcus

Ishaan empire, Shivam industrial zone - 2, kalavad road, Rajkot - Gujarat 360021.